



## An Introduction to Spectrum Analyzer



**GW INSTEK**

Made to Measure Since 1975

### Chapter 1. Introduction

As a result of rapidly advancement in communication technology, all the mobile technology of applications has significantly and profoundly influenced our lifestyle since military began to adopt the traditional communication system in World War II. To implement the relevant scientific theory and engineering basis, all need to resort to fulfilling the RF signal measurement to attain the desired achievements in communication. This application note is intentionally provided as an entrance to comprehend on spectrum analyzer. This kind of analyzer can be characterized as the roles proximal to frequency counter and power meter calibrated to the RMS value of a sinusoidal waveform. Actually, it is worthwhile emphasizing that spectrum analyzer can behave as the functions more than frequency counter and power meter do in many aspects of complicated measurements.

### What measurement information comes from a spectrum analysis?

In order to smoothly proceed in practical measurement work for a RF signal, it is necessary for an engineer to understand notions of the spectrum before touching operation principle of spectrum analyzer at the first time. As an ubiquitous phenomenon existing around this physical world to know about distribution of the signal with different frequencies, we often inspect events of the signal waveform from time horizon on an oscilloscope screen. Thus, an oscilloscope can act as a measurement device to capture any instantaneous physical state of the desired waveform. The genetic development of spectrum analyzer is from the precedent experiment relevant to measuring the frequency for communication system in signal detection with frequency domain. Since then, measurements in frequency domain

facilitate to develop this kind of analyzer in acquiring various parameters of modern communication systems, including average noise level, dynamic range, and frequency range, and so on. Besides, the measurements in time domain also enable the functions to achieve the transmitted output power. Therefore, in aspect to measurement function, spectrum analyzer perform superior to frequency counter, power meter, and traditional frequency analyzer.

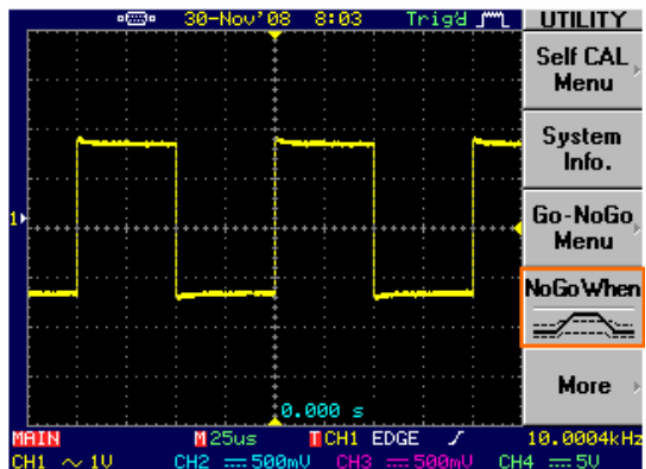
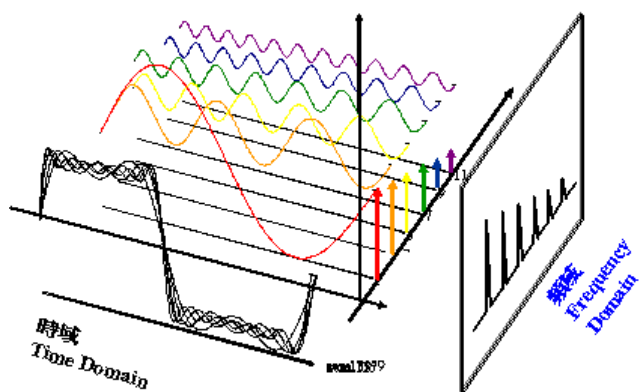

Fig.1. A complex signal analysis proceeds in time domain, for example, square wave

It is important for RF engineers to require information mining for detailed analysis from the measurement in frequency domain, although inspecting waveform state of a signal can be easily gained from a traditional oscilloscope.

Using oscilloscope to characterize the whole picture for waveform state of a signal can be insufficient for further diagnosis, as a desired signal is often composed of the various component signals. Any waveform state of a signal event in time domain consists of many component signals which can be sine wave with associated frequency, amplitude, and phase.

Hence, theoretically all these decomposed components as sine wave with associated frequency, amplitude, and phase can be investigated separately to determine the characteristics of the desired signal. On the other hand, we may transform all the analysis of sine waves in time domain into the measurements in frequency domain by using this component analysis. With the interpretation of Fourier's theory, one can clearly digest what the differences of periodic signal analysis in between time domain and frequency domain. In order to transform the signal analysis from time domain to frequency domain, one has to proceed in the successive calculations and can only observe the fragmentary behaviors of desired signal.



**Fig. 2. Comparison of signal analysis between time domain and frequency domain**

Using Fourier Transform allow us to bring about more depth thinking in many aspects of signal diagnosis, which requires a framework to evaluate each component frequency and phase for a signal event along the entire frequency range. For example, a square wave in time domain being transformed into frequency domain and then transformed back to time domain would often result in saw tooth wave as a distortion without preserving the exact phase.

As depicted in Fig.2, all the characteristics of sine wave in the frequency domain can be expressed by amplitude and frequency. Through the spectrum as shown, we may understand that the impure sine wave contained a second harmonic, third harmonic, and so on. There often consists of some critical device components including amplifier, oscillator, mixer or filter in a RF circuit, where their electrical behavior cannot easily grasped only by inspecting on an oscilloscope screen. With a spectrum analyzer, the desired frequency response to characterize the circuit can be easily acquired.

**Why to carry on a measurement with a spectrum?**

In addition to the amplitude analysis in traditional time domain, there also provides with the amplitude measurement in frequency domain. Thus, with the amplitude analysis, spectrum analysis is the optimal solution to diagnose the harmonic components. Especially for engineers involving in the harmonic distortion for communication system, the distortion of message modulated onto a carrier. Third-order inter-modulation could be a significant technical challenge as the distortion portions can lie in the band of relevance and can be filtered out. Thus may affect the message transmission quality around communication systems.

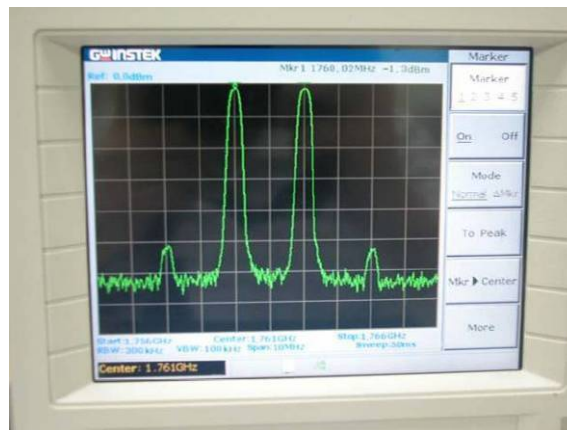

**Fig.3. Mixer Third-order inter-modulation (TOIP) measurement**

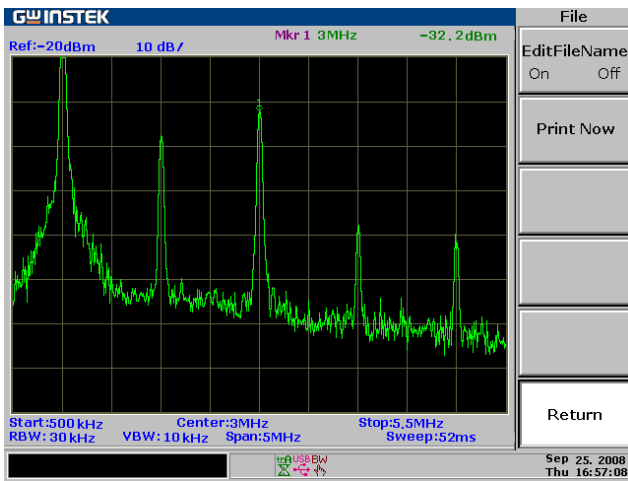

**Fig.4.** With the amplitude analysis, spectrum analysis is the optimal solution to diagnose the harmonic components. Especially for engineers involving in the harmonic distortion for communication system, the distortion of message modulated onto a carrier.

Secondly, spectral occupancy has become more and more pervasive in frequency analysis around our lives. In order to prevent interference with adjacent signals, regulatory agencies restrict the spectra bandwidth of various transmissions. Electromagnetic Interference (EMI) that is ubiquitous around our life space. With the increasing use of electronic product and system to expand the application aspects including avionics, medical instruments, computer equipment and mobile communication product enhance the escalating intensity of system use. Thus may cause the growth of EMI effect around the systems. As shown in Fig.4, in case of boosting the capability to immunize the EMI or inhibit the self-generated EMI so as to reduce the distortion on other electronics, the EMI protection design is more and more significant. With the advancement of high-tech development, the issues of either conducted EMI or radiated EMI come out and diffuse over the broad electronic applications. The increasing operating speed and integrated density of semiconductor devices are

enlarging the higher noise level than before so that many of the distortion sources of signal become hard to detect and recognize. Therefore, it is necessary to build the causes and effects methodology by way of the correct measurement to maintain the electromagnetic compatibility, to target the electromagnetic interference, and to detect radio frequency interference. As depicted in Fig.4, a package for spectrum analyzer with EMI diagnosis kits is the best solution to quickly diagnose EMI issues.

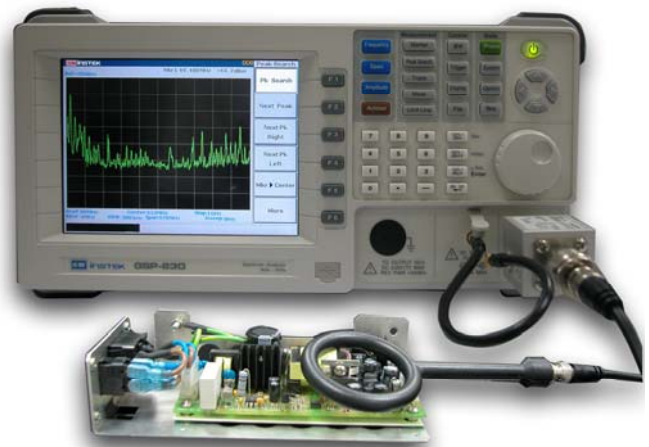
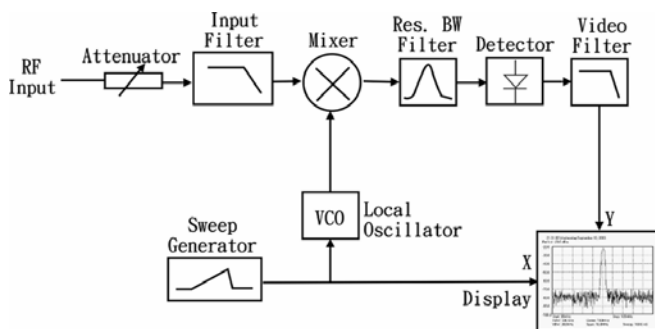

**Fig. 5.** Using a package for spectrum analyzer with a EMI diagnosis kits to execute the pretest will make EMI/EMC certification to pass smoothly.

## Chapter 2. The Super-heterodyne Spectrum Analyzer

The super-heterodyne spectrum analyzer, sometimes called a scanning spectrum analyzer or sweeping spectrum analyzer, operates on the principle of the relative movement in frequency between the signal and a filter. The important parameter is the relative frequency movement. It does not matter whether the signal is stationary and the filter changes or whether the filter is stationary and signal is made to change the frequency. Super-heterodyne spectrum analyzer is the most common type of interest usable up to GHz order range of

frequencies. Almost all modern spectrum analyzers employ the super-heterodyne principle. The fact that it provides better resolution and frequency coverage outweighs the fact that it is more complex than other types of analyzers. The super-heterodyne system is based on the use of a mixer and a local oscillator. The horizontal axis of the LCD can now be transformed from the time domain to the frequency domain by varying the local oscillator frequency in synchronization with the horizontal position voltage. Compared with the tuned filter analyzer performing the time-to-frequency domain transformation by varying the frequency of the filter with respect to the signal, the super-heterodyne analyzer performs this transformation by effectively varying the signal at the mixer output with respect to the filter frequency. A basic super-heterodyne spectrum analyzer uses two mixers, a fixed frequency filter and a variable resolution filter, in addition to other basic components needed to display results on a LCD. Note that the variable resolution filter can be designed with a narrow bandwidth because the signal frequency has been substantially lowered by using two heterodyne stages. The filter is designed to have a bandwidth that can be varied manually. This is an important feature because it is normally desirable to use narrow resolution to observe signals that are close together and wide resolution to observe signals that are far apart.



**Fig. 6. The structure of Super-heterodyne Spectrum Analyzer**

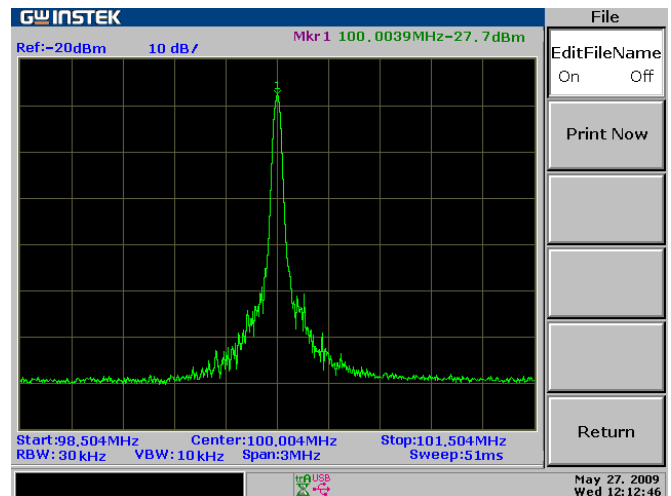

**Fig. 7. General spectrum analyzers are illustrated with the essential settings**

### Spurious and image responses

In a spectrum analyzer, you can have more than one possible output (which should truly represent the spectrum component of the input applied) from the mixing process. This causes components such as (i) IF feed through, and (ii) image response, in addition to the true response. Modern instruments are designed to minimize the effects of these image responses and IF feed through, etc., using appropriate circuitry.

### Control

Most modern spectrum analyzers employ three primary controls. Using these parameter settings including frequency, span per division and reference level, it is possible to make a variety of measurements using only the primary controls, although additional controls are provided. The added controls not only make the analyzer more convenient to use, but also make the analyzer more adaptable to measurement requirements. Many features of modern spectrum analyzers are microprocessors controlled and selectable from on-screen menus. In modern designs microprocessors are used to provide selectable on-screen menus, etc.

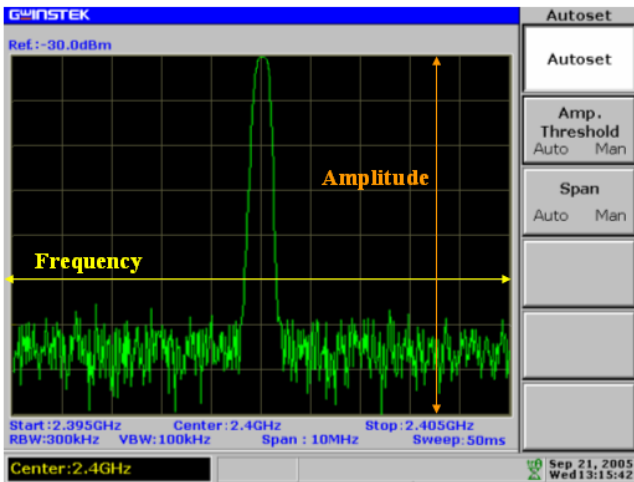

Fig. 8. Using these parameter settings including frequency, span per division and reference level, it is possible to make a variety of measurements using only the primary controls

sweeping the frequency of the first LO over a specified frequency range or span, a corresponding range of input signal frequencies is swept past the resolution or span, a corresponding range of input signal frequencies is swept past the resolution bandwidth (RBW) filter. The frequency control customarily determines the center of the swept frequency range. In other words, the center frequency control adjusts the average ramp voltage that is applied to the tunable oscillator.

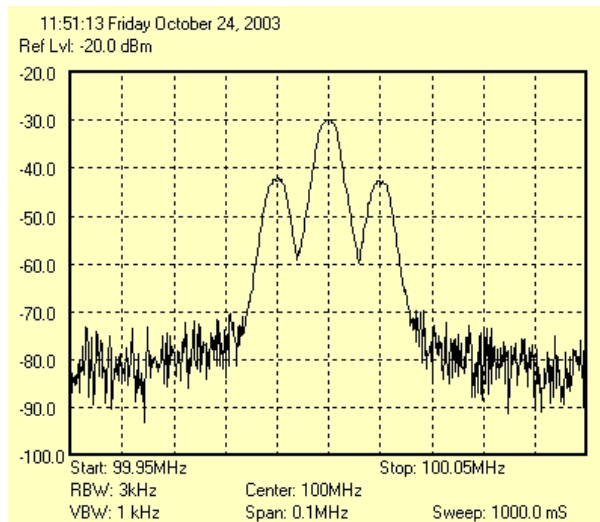

Fig. 9. Frequency Measurement offers different aspect of the signal, AM

### Frequency Control

Scanning spectrum analyzers use a series of local oscillators and mixing circuits to measure the spectrum of the input signal. The first local oscillator (LO) determines the range of input frequencies analyzed. By

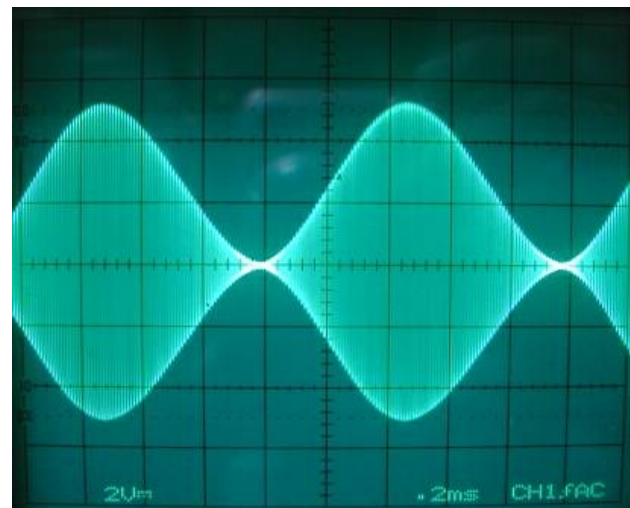

Fig. 10. Amplitude Modulation (AM) from Oscilloscope

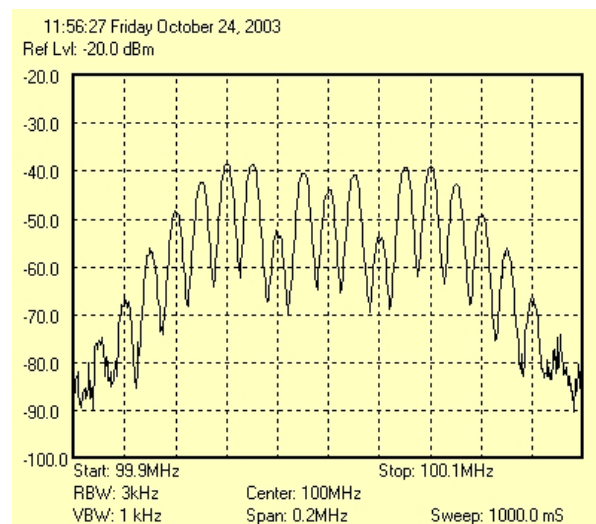

Fig. 11. Frequency Measurement offers different aspect of the signal, FM

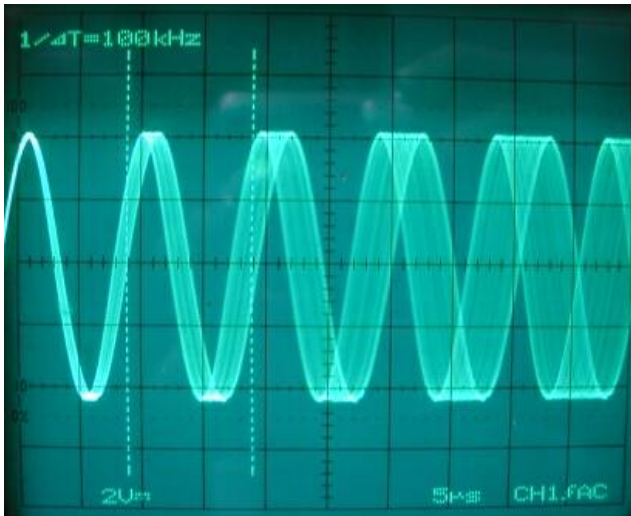

Fig. 12. Frequency Modulation (FM) from Oscilloscope

### Span Control

The span control regulates the width of the frequency spectrum that is displayed by controlling the width of the local oscillator sweep. This control adjusts the amplitude of the ramp voltage. Most spectrum analyzers have two special span control settings. They are maximum span and zero span. At maximum span the analyzer sweep across a spectrum; instead it behaves like a conventional (super-heterodyne) radio receiver. The analyzer is tuned to the center frequency and the signal present in the RBW filter pass band is continuously displayed.

### Reference Level Control

The reference level control varies the level of the signal necessary to produce a full screen display. The reference level is determined by the RF attenuation and the IF gain, but attenuation and gain are controlled by independent sections of the analyzer. To avoid having to operate two controls, most analyzers automatically select the proper amounts of RF attenuation and RF gain. The RF attenuator determines the amount of attenuation the signal encounters just after it enters the analyzer. For

optimum performance, the input signal reaching the first mixer must be attenuated to a level specified. Exceeding the specified first mixer input level can result in distortion and spurious signal products, or in extreme cases, damage to the mixer. All analyzers have a maximum input level that must not be exceeded.

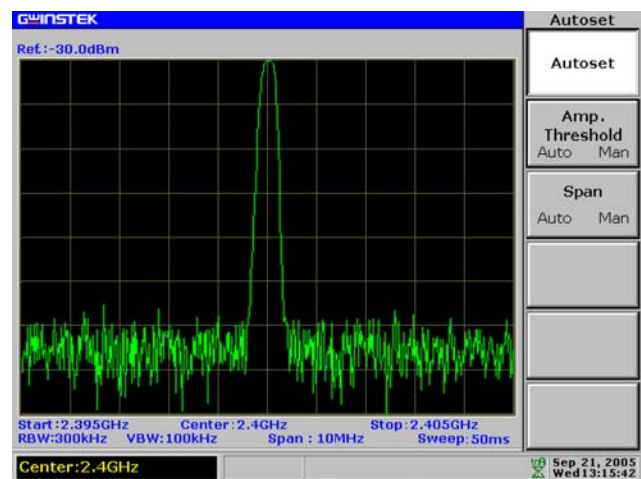
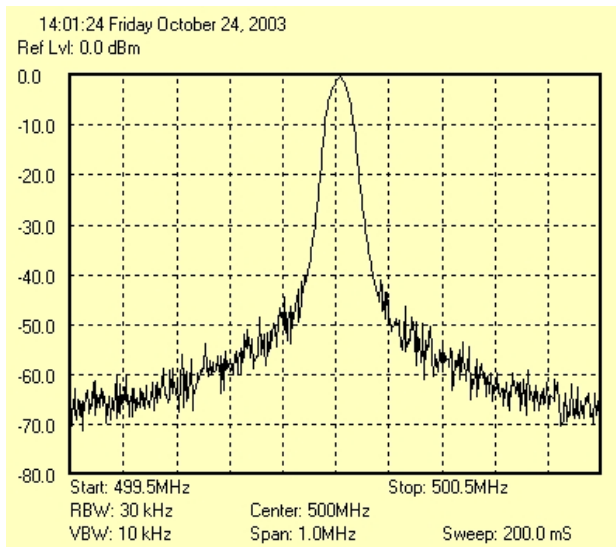

Fig. 13. The amplitude and span can be assigned and functioned in manual mode.

### Other Controls

Here it is assumed that system operation is based on a mixer output composed of the difference frequency between local oscillator and signal. A constant frequency signal is converted to a frequency saw-tooth by combining it in a mixer with a frequency saw-tooth from the swept local oscillator. In the example, it was assumed that the mixer output consists of the difference frequency between the local oscillator frequency saw-tooth and the output. Other combinations, such as the sum of the frequencies, lead to similar diagrams. The display consists of pulses whose time position is determined by the time of interval during which the sweeping signal frequency is within the filter passband.



**Fig. 14. The system operation is based on a mixer output composed of the difference frequency between local oscillator and signal.**

The bursts or pulses generated by the relative translation of signal and filter are pseudo-impulses representing the frequency domain characteristics of the signal. Whereas the time position of these pulses represents the input signal frequency and is determined by the incoming signal, the width of these pulses is determined solely by the spectrum analyzers. The width is equal to the time that the sweeping signal frequency is within the passband of the filter.

### Resolution Bandwidth Selection

Resolution bandwidth (RBW) filters are bandpass filters located in the spectrum analyzer's final IF stages. They determined how well closely spaced signals can be separated. The narrower the RBW filter the more clearly two close signals can be seen as separate signals. The RBW filters also determined the analyzer response to pulse signals and to noise. The resolution bandwidth control selects which RBW filter is used. The shape of a

spectrum displayed on the analyzer screen is a combination of the shape of the RBW filter and the shape of the true signal spectrum. Thus, the measured analyzer response to two sine wave signals with equal amplitude that are one RBW apart in frequency. RBW filters are defined by their bandwidths and shape factors. The shape factor, which indicates the steepness of the filter, is the ratio of the RBW filter bandwidth 60 dB down from the peak to its normal (3dB or 6dB) bandwidth. The shape factor is important in determining the minimum separation between two signals which have equal amplitudes to be resolved. Ideally, RBW filters should be extremely narrow in order to trace out signal spectral shapes faithfully and to resolve very closely spaced signals. The smaller the ratio the shaper the filter. However, using a narrow RBW filter with a wide span results in a signal sweep that is too long. Therefore, to main reasonable speeds the resolution bandwidth must increase as the span  $div^{-1}$  increases.

Another characteristic associated with RBW filters is the decrease in displayed noise floor as the bandwidth is narrowed. The noise floor is the baseline or lowest horizontal part of the trace. The noise floor decreases because noise power is proportional to bandwidth. A change in the bandwidth of the RBW filter by a factor of 10 should decrease the noise floor by about 10dB. The reduction in the noise floor works to advantage when we are looking for low level narrow band signals. The limitations imposed on a spectrum analyzer by the RBW filter are significant. Through the use of microprocessors, modern spectrum analyzers automatically choose the best resolution bandwidth as a function of the span  $div^{-1}$  and sweep rate selected.

### Sweep control/use of video filters and display storage

The sweep control selects the sweep speed at which the spectrum is swept and displayed. Sweep speed units are in time per division (div); a typical value might be 20 ms  $div^{-1}$ . The control can be either manually or auto-selected. Automatic selection is the normal setting for sweep control and, in this case, as with the automatic selection of RBW, most analyzers can automatically select the optimal sweep speed, depending on the other parameter settings such as span, RBW and video filter BW. If manually selected, one should bear in mind that too fast a sweep speed may cause inaccurate measurements owing to the RBW filter not having sufficient time to charge. When swept too slowly the display accuracy is not affected but the display may flicker objectionably or fade out entirely before the start of the next sweep. Flicker and fade out can be overcome using display storage. A video filter is a post-detection filter and it is used primarily to reduce noise in the displayed spectrum. The sensitivity of a spectrum analyzer can be specified as that condition at which the signal level equals the displayed average noise level. This is the level where the signal appears to be approximately 3dB above the average noise level.

In using video filters care should be taken as they may also reduce the signal amplitude in certain types of signals such as video modulation and short duration pulses, most analyzers provide several video filter bandwidths. The video filter control enables the user to turn the filter on and off and to select its bandwidth. As with the RBW and sweep controls many analyzers can automatically select the video filter bandwidth. "Auto" is the normal setting for this control.

### Use of a tracking generator with a spectrum analyzer

A tracking generator is a signal generator whose output frequency is synchronized to, or tracks with, the frequency being analyzed at any point in time. When used with a spectrum analyzer, a tracking generator allows the frequency response of systems to be measured over a very wide dynamic range. The measurements are performed by connecting the output of the tracking generator to the input of the device being tested, and monitoring the output of the DUT with the spectrum analyzer. A tracking generator is an oscillator/mixer combination that uses the local oscillator outputs of the spectrum analyzer.

Global Headquarters

**GOOD WILL INSTRUMENT CO., LTD.**

No. 7-1, Jhongsing Road, Tucheng City, Taipei County 236, Taiwan  
T +886-2-2268-0389 F +886-2-2268-0639  
E-mail: marketing@goodwill.com.tw

China Subsidiary

**INSTEK ELECTRONIC (SHANGHAI) CO., LTD.**

8F, of NO.2 Building, No.889 Yishan Road, Shanghai China  
T +86-21-6485-3399 F +86-21-5450-0789  
E-mail: marketing@instek.com.cn

Malaysia Subsidiary

**GOOD WILL INSTRUMENT (M) SDN. BHD.**

27, Persiaran Mahsuri 1/1, Sunway Tunas,  
11900 Bayan Lepas, Penang, Malaysia.  
T +604-6309988 F +604-6309989  
E-mail: sales@goodwill.com.my

U.S.A. Subsidiary

**INSTEK AMERICA CORP.**

3661 Walnut Avenue Chino, CA 91710, U.S.A.  
T +1-909-5918358 F +1-909-5912280  
E-mail: sales@instek.com

Japan Subsidiary

**INSTEK JAPAN CORPORATION**

4F, Prosper Bldg, 1-3-3 Iwamoto-Cho Chiyoda-Ku,  
Tokyo 101-0032 Japan  
T +81-3-5823-5656 F +81-3-5823-5655  
E-mail: info@instek.co.jp

Korea Subsidiary

**GOOD WILL INSTRUMENT KOREA CO., LTD.**

Room No.805, Ace Hightech-City B/D 1Dong,  
Mullae-Dong 3Ga 55-20, Yeongduengpo-Gu, Seoul, Korea  
T +82 2 3439 2205 F +82 2 3439 2207  
E-mail : gwinstek@gwinstek.co.kr

**DISTRIBUTOR :**



sales@shany-tech.com

04-6270164